

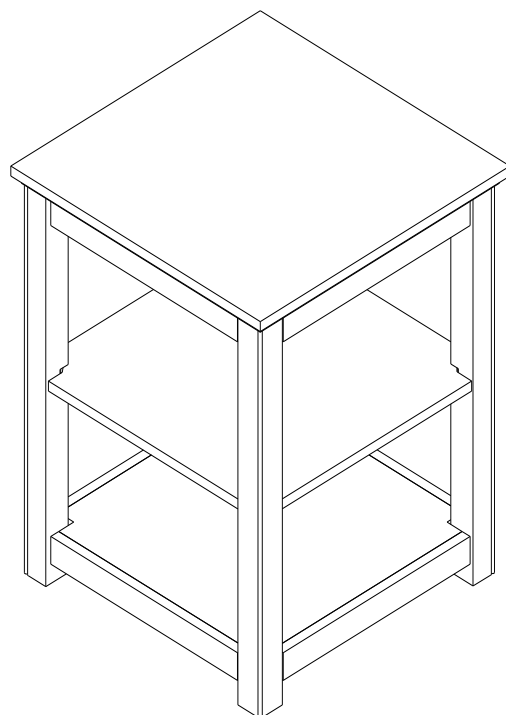





Painted Farmhouse 2 Shelf End Table - OTNQ3 & OTNQ4

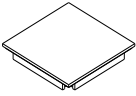

Thank you for purchasing our 2 Shelf End Table. It is helpful to have a second person available during the assembly of this product.

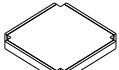
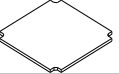
Lay out parts on a non-abrasive surface to avoid scratching finish.

NO.	DRAWING	DESCRIPTION	QTY.
A		TOP	1
B		POST	4
C		BOTTOM	1
D		SHELF	1

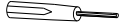
NO.	DRAWING	DESCRIPTION	QTY.
E		M6*45MM BOLT	8
F		WRENCH	1

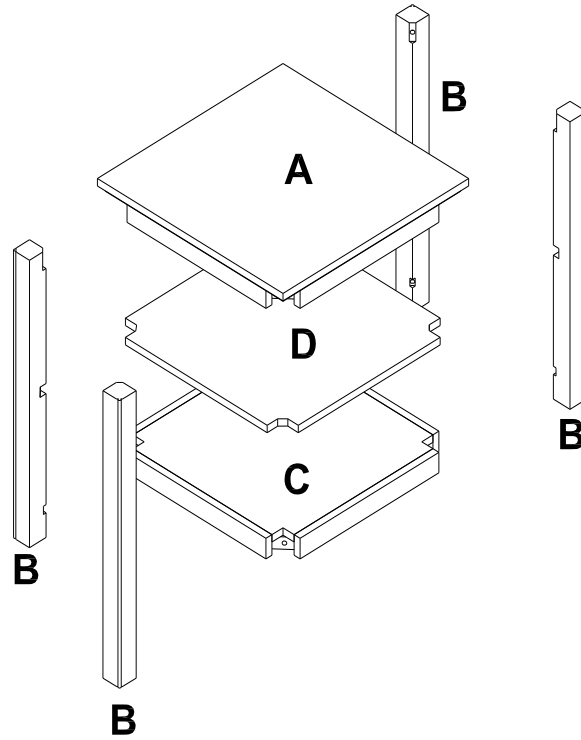

STEP 1

Identify and count all parts using diagram above.

STEP 2

Identify and count hardware.

STEP 3

Position Top Assembly (A) upside down on non-abrasive surface. Attach 2 Post (B) using 2 M6 * 45MM Bolts (E). Use Wrench (F) to install Bolts.

**Do not over tighten Bolts at this time.
Assemble Loose.**

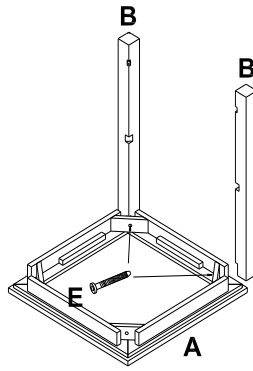

STEP 4

Align Shelf (D) with slots in Post (B). Attach 2 additional Post (B) using 2 M6 * 45MM Bolts (E). Use Wrench (F) to install Bolts.

**Do not over tighten Bolts at this time.
Assemble Loose.**

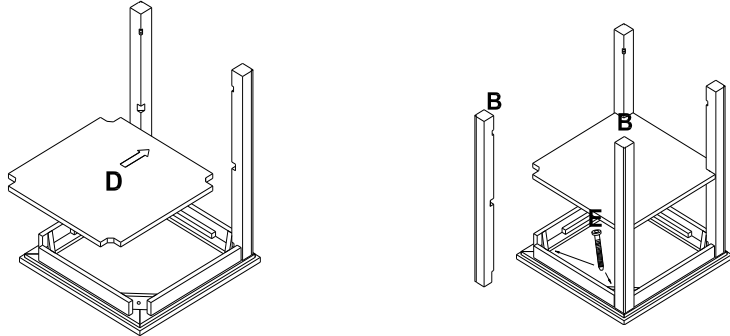

STEP 5

Position Bottom Panel (C) between the 4 Post (B). Attach Bottom Shelf (C) to Post using 4 M6 * 45MM Bolts (E). Use Wrench (F) to install and tighten all Bolts.

At this point tighten all assembly Bolts.

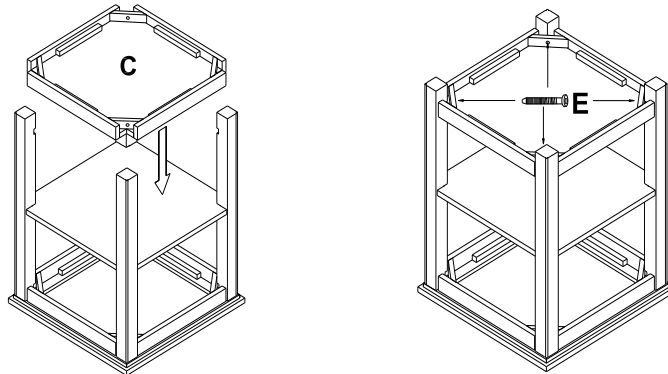

STEP 6

Position assembled case upright.

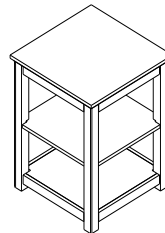

CARE: Clean with mild soap and wipe dry.



www.llbean.com

Product Support 1 800 341 4341

Pntd Frmhs 2 Shelf End Table